

The Kokkos Lectures

Module 2: Views and Spaces

May 20, 2026

Sandia National Laboratories is a multi-mission laboratory managed and operated by National Technology and Engineering Solutions of Sandia, LLC., a wholly owned subsidiary of Honeywell International, Inc., for the U.S. Department of Energy's National Nuclear Security Administration under contract DE-NA0003525.
SAND2020-7475 PE

Online Resources:

- ▶ <https://github.com/kokkos>:
 - ▶ Primary Kokkos GitHub Organization
- ▶ <https://kokkos.org/kokkos-core-wiki/videolectures.html>
 - ▶ Slides, recording and Q&A for the lectures
- ▶ <https://kokkos.org/kokkos-core-wiki>:
 - ▶ Programming guide and API reference documentation
- ▶ <https://kokkosteam.slack.com>:
 - ▶ Slack channel for Kokkos.
 - ▶ Please join: fastest way to get your questions answered.
 - ▶ Can whitelist domains, or invite individual people.

- ▶ Module 1: Introduction, Building and Parallel Dispatch
- ▶ **Module 2: Views and Spaces**
- ▶ Module 3: Data Structures + MultiDimensional Loops
- ▶ Module 4: Hierarchical Parallelism
- ▶ Module 5: Tasking, Streams and SIMD
- ▶ Module 6: Internode: MPI and PGAS
- ▶ Module 7: Tools: Profiling, Tuning and Debugging
- ▶ Module 8: Kernels: Sparse and Dense Linear Algebra
- ▶ Module 9: Fortran inter-op

Kokkos Ecosystem:

- ▶ C++ Performance Portability Programming Model.
- ▶ The Kokkos Ecosystem provides capabilities needed for serious code development.
- ▶ Kokkos is supported by multiple National Laboratories with a sizeable dedicated team.

Building Kokkos

- ▶ Kokkos's primary build system is CMAKE.
- ▶ Kokkos options are transitively passed on, including many necessary compiler options.
- ▶ The Spack package manager does support Kokkos.
- ▶ For applications with few if any dependencies, building Kokkos as part of your code is an option with CMake and GNU Makefiles.

Data Parallelism:

- ▶ Simple things stay simple!
- ▶ You use **parallel patterns** and **execution policies** to execute **computational bodies**
- ▶ Simple parallel loops use the `parallel_for` pattern:

```
parallel_for("Label", N, [=] (int64_t i) {  
    /* loop body */  
});
```

- ▶ Reductions combine contributions from loop iterations

```
int result;  
parallel_reduce("Label", N, [=] (int64_t i, int& lres) {  
    /* loop body */  
    lres += /* something */  
}, result);
```

Recording: <https://bit.ly/kokkos-lecture-series-1>

Kokkos View

What are Views? How to create them? Why should you use it?

Memory and Execution Spaces

How to control where data lives and code executes.

Memory Access Patterns

The importance of access patterns for performance portability and how to control it.

Advanced Reductions

Going beyond just basic summation.

Views

Learning objectives:

- ▶ Motivation behind the `View` abstraction.
- ▶ Key `View` concepts and template parameters.
- ▶ The `View` life cycle.

Example: running daxpy on the GPU:

Lambda

```
double * x = new double[N]; // also y
parallel_for("DAXPY",N, [=] (const int64_t i) {
    y[i] = a * x[i] + y[i];
});
```

Functor

```
struct Functor {
    double *_x, *_y, a;
    void operator()(const int64_t i) const {
        _y[i] = _a * _x[i] + _y[i];
    }
};
```

Example: running daxpy on the GPU:

Lambda

```
double * x = new double[N]; // also y
parallel_for("DAXPY",N, [=] (const int64_t i) {
    y[i] = a * x[i] + y[i];
});
```

Functor

```
struct Functor {
    double *_x, *_y, a;
    void operator()(const int64_t i) const {
        _y[i] = _a * _x[i] + _y[i];
    }
};
```

Problem: x and y reside in CPU memory.

Example: running daxpy on the GPU:

Lambda

```
double * x = new double[N]; // also y
parallel_for("DAXPY",N, [=] (const int64_t i) {
    y[i] = a * x[i] + y[i];
});
```

Functor

```
struct Functor {
    double *_x, *_y, a;
    void operator()(const int64_t i) const {
        _y[i] = _a * _x[i] + _y[i];
    }
};
```

Problem: x and y reside in CPU memory.

Solution: We need a way of storing data (multidimensional arrays) which can be communicated to an accelerator (GPU).

⇒ **Views**

View abstraction

- ▶ A *lightweight* C++ class with a pointer to array data and a little meta-data,
- ▶ that is *templated* on the data type (and other things).

High-level example of Views for daxpy using lambda:

```
View<double*, ...> x(...), y(...);
...populate x, y...

parallel_for("DAXPY",N, [=] (const int64_t i) {
    // Views x and y are captured by value (shallow copy)
    y(i) = a * x(i) + y(i);
});
```

View abstraction

- ▶ A *lightweight* C++ class with a pointer to array data and a little meta-data,
- ▶ that is *templated* on the data type (and other things).

High-level example of Views for daxpy using lambda:

```
View<double*, ...> x(...), y(...);  
...populate x, y...  
  
parallel_for("DAXPY",N, [=] (const int64_t i) {  
    // Views x and y are captured by value (shallow copy)  
    y(i) = a * x(i) + y(i);  
});
```

Important point

Views are **like pointers**, so copy them in your functors.

View overview:

- ▶ **Multi-dimensional array** of 0 or more dimensions
scalar (0), vector (1), matrix (2), etc.
- ▶ **Number of dimensions (rank)** is fixed at compile-time.
- ▶ Arrays are **rectangular**, not ragged.
- ▶ **Sizes of dimensions** set at compile-time or runtime.
e.g., 2x20, 50x50, etc.
- ▶ Access elements via "`(...)`" operator.

View overview:

- ▶ **Multi-dimensional array** of 0 or more dimensions
scalar (0), vector (1), matrix (2), etc.
- ▶ **Number of dimensions (rank)** is fixed at compile-time.
- ▶ Arrays are **rectangular**, not ragged.
- ▶ **Sizes of dimensions** set at compile-time or runtime.
e.g., 2x20, 50x50, etc.
- ▶ Access elements via "(...)" operator.

Example:

```
View<double***> data("label", N0, N1, N2); //3 run, 0 compile
View<double**[N2]> data("label", N0, N1); //2 run, 1 compile
View<double*[N1][N2]> data("label", N0); //1 run, 2 compile
View<double[N0][N1][N2]> data("label"); //0 run, 3 compile
//Access
data(i,j,k) = 5.3;
```

Note: runtime-sized dimensions must come first.

View life cycle:

- ▶ Allocations only happen when *explicitly* specified.
i.e., there are **no hidden allocations**.
- ▶ Copy construction and assignment are **shallow** (like pointers).
so, you pass Views by value, *not* by reference
- ▶ Reference counting is used for **automatic deallocation**.
- ▶ They behave like `std::shared_ptr`

View life cycle:

- ▶ Allocations only happen when *explicitly* specified.
i.e., there are **no hidden allocations**.
- ▶ Copy construction and assignment are **shallow** (like pointers).
so, you pass Views by value, *not* by reference
- ▶ Reference counting is used for **automatic deallocation**.
- ▶ They behave like `std::shared_ptr`

Example:

```
View<double*[5]> a("a", N), b("b", K);  
a = b;  
View<double**> c(b);  
a(0,2) = 1;  
b(0,2) = 2;  
c(0,2) = 3;  
print_value( a(0,2) );
```

What gets printed?

View life cycle:

- ▶ Allocations only happen when *explicitly* specified.
i.e., there are **no hidden allocations**.
- ▶ Copy construction and assignment are **shallow** (like pointers).
so, you pass Views by value, *not* by reference
- ▶ Reference counting is used for **automatic deallocation**.
- ▶ They behave like `std::shared_ptr`

Example:

```
View<double*[5]> a("a", N), b("b", K);
a = b;
View<double**> c(b);
a(0,2) = 1;
b(0,2) = 2;
c(0,2) = 3;
print_value( a(0,2) );
```

What gets printed?

3.0

View Properties:

- ▶ Accessing a View's sizes is done via its `extent(dim)` function.
 - ▶ Static extents can *additionally* be accessed via `static_extent(dim)`.
- ▶ You can retrieve a raw pointer via its `data()` function.
- ▶ The label can be accessed via `label()`.

Example:

```
View<double*[5]> a("A",N0);
assert(a.extent(0) == N0);
assert(a.extent(1) == 5);
static_assert(a.static_extent(1) == 5);
assert(a.data() != nullptr);
assert(a.label() == "A");
```

Exercise #2: Inner Product, Flat Parallelism on the CPU, with Views

- ▶ Location: Exercises/02/Begin/
- ▶ Assignment: Change data storage from arrays to Views.
- ▶ Compile and run on CPU, and then on GPU with SharedSpace.

```
# CPU-only using OpenMP
cmake -B build_openmp -DKokkos_ENABLE_OPENMP=ON
cmake --build build_openmp
# Run exercise
./build_openmp/02_Exercise -S 26
# Note the warnings, set appropriate environment variables
```

- ▶ Vary problem size: **-S #**
- ▶ Vary number of rows: **-N #**
- ▶ Vary repeats: **-nrepeat #**
- ▶ Compare performance of CPU vs GPU

- ▶ **Memory space** in which view's data resides; *covered next*.
- ▶ **deep_copy** view's data; *covered later*.
Note: Kokkos *never* hides a deep_copy of data.
- ▶ **Layout** of multidimensional array; *covered later*.
- ▶ **Memory traits**; *covered later*.
- ▶ **Subview**: Generating a view that is a “slice” of other multidimensional array view; *covered later*.

Execution and Memory Spaces

Learning objectives:

- ▶ Heterogeneous nodes and the **space** abstractions.
- ▶ How to control where parallel bodies are run, **execution space**.
- ▶ How to control where view data resides, **memory space**.
- ▶ How to avoid illegal memory accesses and manage data movement.
- ▶ The need for `Kokkos::initialize` and `finalize`.
- ▶ Where to use Kokkos annotation macros for portability.

Execution Space

a homogeneous set of cores and an execution mechanism
(i.e., “place to run code”)

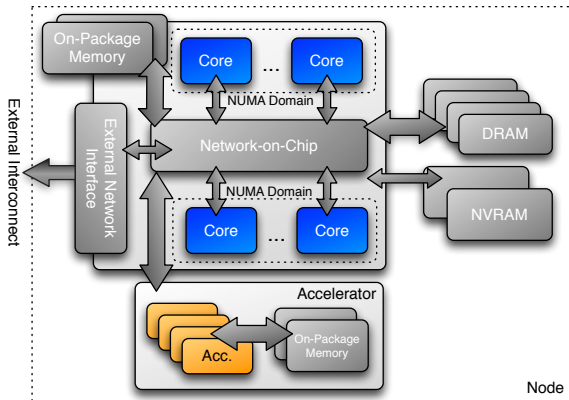

Execution spaces: Serial, Threads, OpenMP, Cuda, HIP, ...

```
Host MPI_Reduce(...);  
FILE * file = fopen(...);  
runANormalFunction(...data...);  
Parallel Kokkos::parallel_for("MyKernel", numberOfSomethings,  
                                [=] (const int64_t somethingIndex) {  
                                    const double y = ...;  
                                    // do something interesting  
                                }  
);
```

```
Host
MPI_Reduce(...);
FILE * file = fopen(...);
runANormalFunction(...data...);

Parallel
Kokkos::parallel_for("MyKernel", numberOfSomethings,
                    [=] (const int64_t somethingIndex) {
                        const double y = ...;
                        // do something interesting
                    }
                    );
```

- ▶ Where will **Host** code be run? CPU? GPU?
 - ⇒ Always in the **host process**
also known as **default host execution space**

```
Host
MPI_Reduce(...);
FILE * file = fopen(...);
runANormalFunction(...data...);

Parallel
Kokkos::parallel_for("MyKernel", numberOfSomethings,
                    [=] (const int64_t somethingIndex) {
                        const double y = ...;
                        // do something interesting
                    }
                    );
```

- ▶ Where will **Host** code be run? CPU? GPU?
 - ⇒ Always in the **host process**
also known as **default host execution space**
- ▶ Where will **Parallel** code be run? CPU? GPU?
 - ⇒ The **default execution space**

```

Host
MPI_Reduce(...);
FILE * file = fopen(...);
runANormalFunction(...data...);

Parallel
Kokkos::parallel_for("MyKernel", numberOfSomethings,
                    [=] (const int64_t somethingIndex) {
                        const double y = ...;
                        // do something interesting
                    }
                    );

```

- ▶ Where will **Host** code be run? CPU? GPU?
 - ⇒ Always in the **host process**
also known as **default host execution space**
- ▶ Where will **Parallel** code be run? CPU? GPU?
 - ⇒ The **default execution space**
- ▶ How do I **control** where the **Parallel** body is executed?
 - Changing the default execution space (*at compilation*),
or specifying an execution space in the **policy**.

Changing the parallel execution space:

Custom

```
parallel_for("Label",  
    RangePolicy< ExecutionSpace >(0,numberOfIntervals),  
    [=] (const int64_t i) {  
        /* ... body ... */  
    });
```

Default

```
parallel_for("Label",  
    numberOfIntervals, // => RangePolicy<>(0,numberOfIntervals)  
    [=] (const int64_t i) {  
        /* ... body ... */  
    });
```

Changing the parallel execution space:

Custom

```
parallel_for("Label",
  RangePolicy< ExecutionSpace >(0, numberOfIntervals),
  [=] (const int64_t i) {
    /* ... body ... */
  });
```

Default

```
parallel_for("Label",
  numberOfIntervals, // => RangePolicy<>(0, numberOfIntervals)
  [=] (const int64_t i) {
    /* ... body ... */
  });
```

Requirements for enabling execution spaces:

- ▶ Kokkos must be **compiled** with the execution spaces enabled.
- ▶ Execution spaces must be **initialized** (and **finalized**).
- ▶ **Functions** must be marked with a **macro** for non-CPU spaces.
- ▶ **Lambdas** must be marked with a **macro** for non-CPU spaces.

Kokkos function and lambda portability annotation macros:

Function annotation with KOKKOS_INLINE_FUNCTION macro

```
struct ParallelFunctor {
  KOKKOS_INLINE_FUNCTION
  double helperFunction(const int64_t s) const {...}
  KOKKOS_INLINE_FUNCTION
  void operator()(const int64_t index) const {
    helperFunction(index);
  }
}

// Where kokkos defines:
#define KOKKOS_INLINE_FUNCTION inline // if CPU only
#define KOKKOS_INLINE_FUNCTION inline __device__ __host__ // if CPU + Cuda/HIP
```

Kokkos function and lambda portability annotation macros:

Function annotation with KOKKOS_INLINE_FUNCTION macro

```

struct ParallelFunctor {
  KOKKOS_INLINE_FUNCTION
  double helperFunction(const int64_t s) const {...}
  KOKKOS_INLINE_FUNCTION
  void operator()(const int64_t index) const {
    helperFunction(index);
  }
}

// Where kokkos defines:
#define KOKKOS_INLINE_FUNCTION inline // if CPU only
#define KOKKOS_INLINE_FUNCTION inline __device__ __host__ // if CPU + Cuda/HIP

```

Lambda annotation with KOKKOS_LAMBDA macro

```

Kokkos::parallel_for("Label", numberOfIterations,
  KOKKOS_LAMBDA (const int64_t index) {...});

// Where Kokkos defines:
#define KOKKOS_LAMBDA [=] // if CPU only
#define KOKKOS_LAMBDA [=] __device__ __host__ // if CPU + Cuda/HIP

```

These macros are *already* defined by Kokkos.

Memory space motivating example: summing an array

```
View<double*> data("data", size);
for (int64_t i = 0; i < size; ++i) {
    data(i) = ...read from file...
}

double sum = 0;
Kokkos::parallel_reduce("Label",
    RangePolicy<SomeExampleExecutionSpace>(0, size),
    KOKKOS_LAMBDA (const int64_t index, double & valueToUpdate) {
        valueToUpdate += data(index);
    },
    sum);
```

Memory space motivating example: summing an array

```
View<double*> data("data", size);
for (int64_t i = 0; i < size; ++i) {
    data(i) = ...read from file...
}

double sum = 0;
Kokkos::parallel_reduce("Label",
    RangePolicy<SomeExampleExecutionSpace>(0, size),
    KOKKOS_LAMBDA (const int64_t index, double & valueToUpdate) {
        valueToUpdate += data(index);
    },
    sum);
```

Question: Where is the data stored? GPU memory? CPU memory? Both?

Memory space motivating example: summing an array

```
View<double*> data("data", size);
for (int64_t i = 0; i < size; ++i) {
    data(i) = ...read from file...
}

double sum = 0;
Kokkos::parallel_reduce("Label",
    RangePolicy<SomeExampleExecutionSpace>(0, size),
    KOKKOS_LAMBDA (const int64_t index, double & valueToUpdate) {
        valueToUpdate += data(index);
    },
    sum);
```

Question: Where is the data stored? GPU memory? CPU memory? Both?

Memory space motivating example: summing an array

```
View<double*> data("data", size);
for (int64_t i = 0; i < size; ++i) {
    data(i) = ...read from file...
}

double sum = 0;
Kokkos::parallel_reduce("Label",
    RangePolicy<SomeExampleExecutionSpace>(0, size),
    KOKKOS_LAMBDA (const int64_t index, double & valueToUpdate) {
        valueToUpdate += data(index);
    },
    sum);
```

Question: Where is the data stored? GPU memory? CPU memory? Both?

⇒ **Memory Spaces**

Memory space:
explicitly-manageable memory resource
(i.e., “place to put data”)

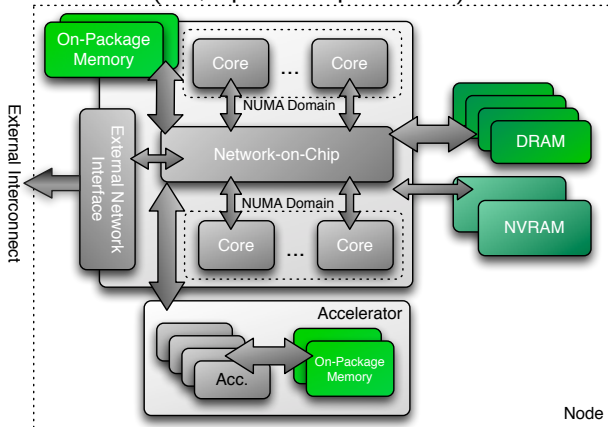

Important concept: Memory spaces

Every view stores its data in a **memory space** set at compile time.

Important concept: Memory spaces

Every view stores its data in a **memory space** set at compile time.

▶ `View<double***, MemorySpace> data(...);`

Important concept: Memory spaces

Every view stores its data in a **memory space** set at compile time.

- ▶ `View<double***, MemorySpace> data(...);`
- ▶ Available **memory spaces**:
 - HostSpace, CudaSpace, CudaUVMSpace, ... more
 - Portable: SharedSpace, SharedHostPinnedSpace

Important concept: Memory spaces

Every view stores its data in a **memory space** set at compile time.

- ▶ `View<double***, MemorySpace> data(...);`
- ▶ Available **memory spaces**:
 - HostSpace, CudaSpace, CudaUVMSpace, ... more
 - Portable: SharedSpace, SharedHostPinnedSpace
- ▶ Each **execution space** has a default memory space, which is used if **Space** provided is actually an execution space

Important concept: Memory spaces

Every view stores its data in a **memory space** set at compile time.

- ▶ `View<double***, MemorySpace> data(...);`
- ▶ Available **memory spaces**:
 - HostSpace, CudaSpace, CudaUVMSpace, ... more
 - Portable: SharedSpace, SharedHostPinnedSpace
- ▶ Each **execution space** has a default memory space, which is used if **Space** provided is actually an execution space
- ▶ If no Space is provided, the view's data resides in the **default memory space** of the **default execution space**.

Important concept: Memory spaces

Every view stores its data in a **memory space** set at compile time.

- ▶ `View<double***, MemorySpace> data(...);`
- ▶ Available **memory spaces**:
 - HostSpace, CudaSpace, CudaUVMSpace, ... more
 - Portable: SharedSpace, SharedHostPinnedSpace
- ▶ Each **execution space** has a default memory space, which is used if **Space** provided is actually an execution space
- ▶ If no Space is provided, the view's data resides in the **default memory space** of the **default execution space**.

```
// Equivalent:  
View<double*> a("A",N);  
View<double*,DefaultExecutionSpace::memory_space> b("B",N);
```

Example: HostSpace

```
View<double**, HostSpace> hostView(...constructor arguments...);
```

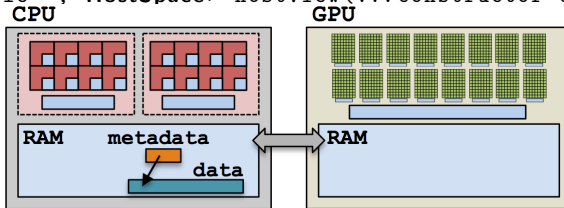

Example: HostSpace

```
View<double**, HostSpace> hostView(...constructor arguments...);
```

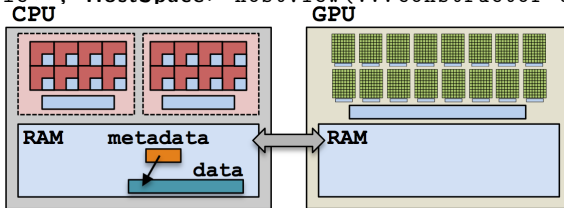

Example: CudaSpace

```
View<double**, CudaSpace> view(...constructor arguments...);
```

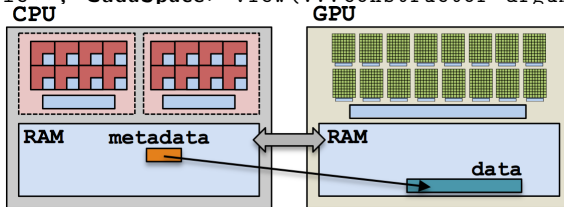

Anatomy of a kernel launch:

1. User declares views, allocating.
2. User instantiates a functor with views.
3. User launches `parallel_something`:
 - ▶ Functor is copied to the device.
 - ▶ Kernel is run.
 - ▶ Copy of functor on the device is released.

```
#define KL KOKKOS_LAMBDA
View<int*, Cuda> dev(...);
parallel_for("Label",N,
  KL (int i) {
    dev(i) = ...;
  });
```

Note: **no deep copies** of array data are performed;
views are like pointers.

Example: one view

```
#define KL KOKKOS_LAMBDA
View<int*, Cuda> dev;
parallel_for("Label",N,
  KL (int i) {
    dev(i) = ...;
  });
```

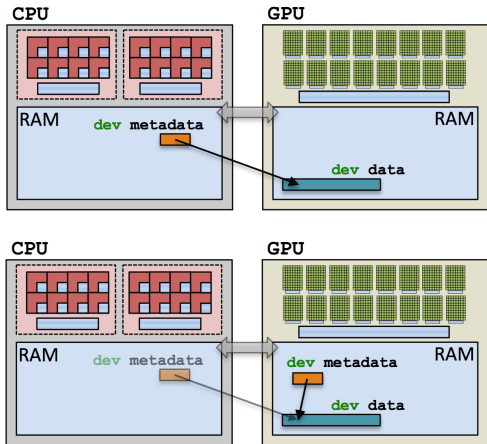

Example: two views

```
#define KL KOKKOS_LAMBDA
View<int*, Cuda> dev;
View<int*, Host> host;
parallel_for("Label",N,
  KL (int i) {
    dev(i) = ...;
    host(i) = ...;
  });
```

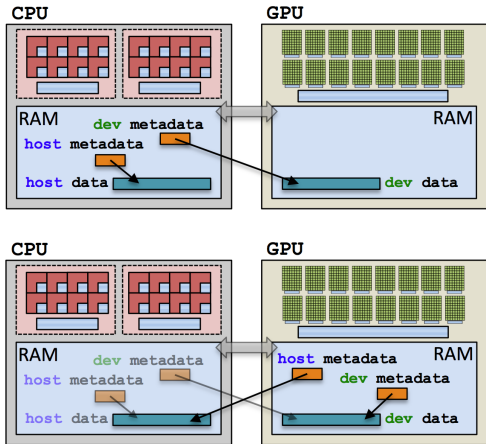

Example: two views

```
#define KL KOKKOS_LAMBDA
View<int*, Cuda> dev;
View<int*, Host> host;
parallel_for("Label", N,
  KL (int i) {
    dev(i) = ...;
    host(i) = ...;
  });
```

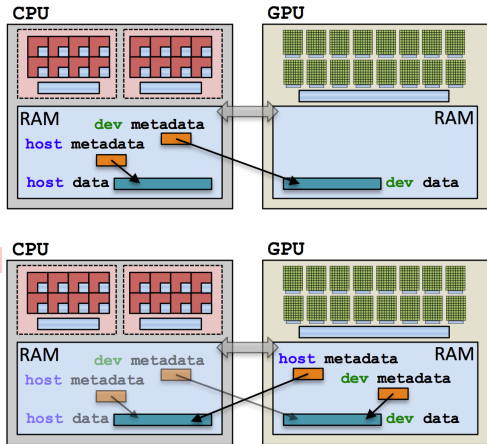

Example (redux): summing an array with the GPU

(failed) Attempt 1: View lives in CudaSpace

```
View<double*, CudaSpace> array("array", size);
for (int64_t i = 0; i < size; ++i) {
    array(i) = ...read from file...
}

double sum = 0;
Kokkos::parallel_reduce("Label",
    RangePolicy< Cuda>(0, size),
    KOKKOS_LAMBDA (const int64_t index, double & valueToUpdate) {
        valueToUpdate += array(index);
    },
    sum);
```

Example (redux): summing an array with the GPU

(failed) Attempt 1: View lives in CudaSpace

```
View<double*, CudaSpace> array("array", size);
for (int64_t i = 0; i < size; ++i) {
    array(i) = ...read from file...          fault
}

double sum = 0;
Kokkos::parallel_reduce("Label",
    RangePolicy< Cuda>(0, size),
    KOKKOS_LAMBDA (const int64_t index, double & valueToUpdate) {
        valueToUpdate += array(index);
    },
    sum);
```

Example (redux): summing an array with the GPU

(failed) Attempt 2: View lives in HostSpace

```
View<double*, HostSpace> array("array", size);
for (int64_t i = 0; i < size; ++i) {
    array(i) = ...read from file...
}

double sum = 0;
Kokkos::parallel_reduce("Label",
    RangePolicy< Cuda>(0, size),
    KOKKOS_LAMBDA (const int64_t index, double & valueToUpdate) {
        valueToUpdate += array(index);
    },
    sum);
```

Example (redux): summing an array with the GPU

(failed) Attempt 2: View lives in HostSpace

```
View<double*, HostSpace> array("array", size);
for (int64_t i = 0; i < size; ++i) {
    array(i) = ...read from file...
}

double sum = 0;
Kokkos::parallel_reduce("Label",
    RangePolicy< Cuda>(0, size),
    KOKKOS_LAMBDA (const int64_t index, double & valueToUpdate) {
        valueToUpdate += array(index);      illegal access
    },
    sum);
```

Example (redux): summing an array with the GPU

(failed) Attempt 2: View lives in HostSpace

```
View<double*, HostSpace> array("array", size);
for (int64_t i = 0; i < size; ++i) {
    array(i) = ...read from file...
}

double sum = 0;
Kokkos::parallel_reduce("Label",
    RangePolicy< Cuda>(0, size),
    KOKKOS_LAMBDA (const int64_t index, double & valueToUpdate) {
        valueToUpdate += array(index);      illegal access
    },
    sum);
```

What's the solution?

- ▶ SharedSpace
- ▶ SharedHostPinnedSpace (skipping)
- ▶ Mirroring

SharedSpace

```

#define KL KOKKOS_LAMBDA
View<double*,
    SharedSpace> array;
array = ...from file...
double sum = 0;
parallel_reduce("Label", N,
    KL (int i, double & d) {
        d += array(i);
    },
    sum);

```

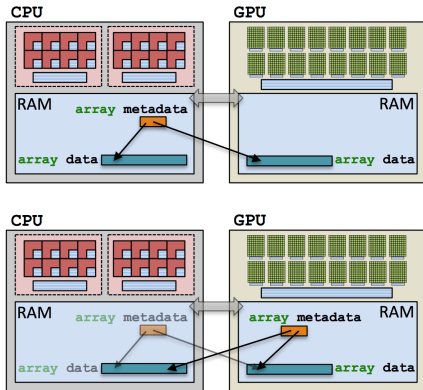

Cuda runtime automatically handles data movement,
at a **performance hit**.

Important concept: Mirrors

Mirrors are views of equivalent arrays residing in possibly different memory spaces.

Important concept: Mirrors

Mirrors are views of equivalent arrays residing in possibly different memory spaces.

Mirroring schematic

```
Kokkos::View<double**, Space> view(...);
auto hostView = Kokkos::create_mirror_view(view);
```

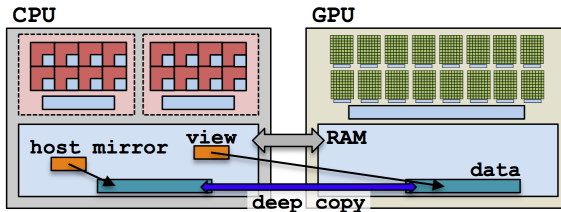

1. Create a `view`'s array in some memory space.

```
Kokkos::View<double*, Space> view(...);
```

1. **Create** a **view**'s array in some memory space.

```
Kokkos::View<double*, Space> view(...);
```

2. **Create** **hostView**, a *mirror* of the **view**'s array residing in the host memory space.

```
auto hostView = Kokkos::create_mirror_view(view);
```

1. **Create** a **view**'s array in some memory space.

```
Kokkos::View<double*, Space> view(...);
```

2. **Create** **hostView**, a *mirror* of the **view**'s array residing in the host memory space.

```
auto hostView = Kokkos::create_mirror_view(view);
```

3. **Populate** **hostView** on the host (from file, etc.).

1. **Create** a `view`'s array in some memory space.

```
Kokkos::View<double*, Space> view(...);
```

2. **Create** `hostView`, a *mirror* of the `view`'s array residing in the host memory space.

```
auto hostView = Kokkos::create_mirror_view(view);
```

3. **Populate** `hostView` on the host (from file, etc.).

4. **Deep copy** `hostView`'s array to `view`'s array.

```
Kokkos::deep_copy(view, hostView);
```

1. **Create** a **view's** array in some memory space.

```
Kokkos::View<double*, Space> view(...);
```

2. **Create** **hostView**, a *mirror* of the **view's** array residing in the host memory space.

```
auto hostView = Kokkos::create_mirror_view(view);
```

3. **Populate** **hostView** on the host (from file, etc.).

4. **Deep copy** **hostView's** array to **view's** array.

```
Kokkos::deep_copy(view, hostView);
```

5. **Launch** a kernel processing the **view's** array.

```
Kokkos::parallel_for("Label",  
    RangePolicy<Space>(0, size),  
    KOKKOS_LAMBDA (...) { use and change view });
```

1. **Create** a **view's** array in some memory space.
`Kokkos::View<double*, Space> view(...);`
2. **Create** **hostView**, a *mirror* of the **view's** array residing in the host memory space.
`auto hostView = Kokkos::create_mirror_view(view);`
3. **Populate** **hostView** on the host (from file, etc.).
4. **Deep copy** **hostView's** array to **view's** array.
`Kokkos::deep_copy(view, hostView);`
5. **Launch** a kernel processing the **view's** array.
`Kokkos::parallel_for("Label",
 RangePolicy<Space>(0, size),
 KOKKOS_LAMBDA (...) { use and change view });`
6. If needed, **deep copy** the **view's** updated array back to the **hostView's** array to write file, etc.
`Kokkos::deep_copy(hostView, view);`

What if the View is in HostSpace too? Does it make a copy?

```
Kokkos::View<double*, Space> view("test", 10);  
auto hostView = Kokkos::create_mirror_view(view);
```

- ▶ `create_mirror_view` allocates data only if the host process cannot access `view`'s data, otherwise `hostView` references the same data.
- ▶ `create_mirror` **always** allocates data.
- ▶ `create_mirror_view_and_copy` allocates data if necessary and also **copies** data.

Reminder: Kokkos *never* performs a **hidden deep copy**.

Exercise #3: Flat Parallelism on the GPU, Views and Host Mirrors

Details:

- ▶ Location: Exercises/03/Begin/
- ▶ Add HostMirror Views and deep copy
- ▶ Make sure you use the correct view in initialization and Kernel

```
# Compile for CPU
cmake -B build_openmp -DKokkos_ENABLE_OPENMP=ON
cmake --build build_openmp
# Run on CPU
./build_openmp/03_Exercise -S 26
# Note the warnings, set appropriate environment variables
# Compile for GPU
cmake -B build_cuda -DKokkos_ENABLE_CUDA=ON
cmake --build build_cuda
# Run on GPU
./build_cuda/03_Exercise -S 26
```

Things to try:

- ▶ Vary problem size and number of rows (-S ...; -N ...)
- ▶ Change number of repeats (-nrepeat ...)
- ▶ Compare behavior of CPU vs GPU

- ▶ Data is stored in Views that are “pointers” to **multi-dimensional arrays** residing in **memory spaces**.
- ▶ Views **abstract away** platform-dependent allocation, (automatic) deallocation, and access.
- ▶ **Heterogeneous nodes** have one or more memory spaces.
- ▶ **Mirroring** is used for performant access to views in host and device memory.
- ▶ Heterogeneous nodes have one or more **execution spaces**.
- ▶ You **control where** parallel code is run by a template parameter on the execution policy, or by compile-time selection of the default execution space.

Managing memory access patterns for performance portability

Learning objectives:

- ▶ How the View's Layout parameter controls data layout.
- ▶ How memory access patterns result from Kokkos mapping parallel work indices **and** layout of multidimensional array data
- ▶ Why memory access patterns and layouts have such a performance impact (caching and coalescing).
- ▶ See a concrete example of the performance of various memory configurations.

Example: inner product (0)

```
Kokkos::parallel_reduce("Label",  
  RangePolicy<ExecutionSpace>(0, N),  
  KOKKOS_LAMBDA (const size_t row, double & valueToUpdate) {  
    double thisRowsSum = 0;  
    for (size_t entry = 0; entry < M; ++entry) {  
      thisRowsSum += A(row, entry) * x(entry);  
    }  
    valueToUpdate += y(row) * thisRowsSum;  
  }, result+).
```

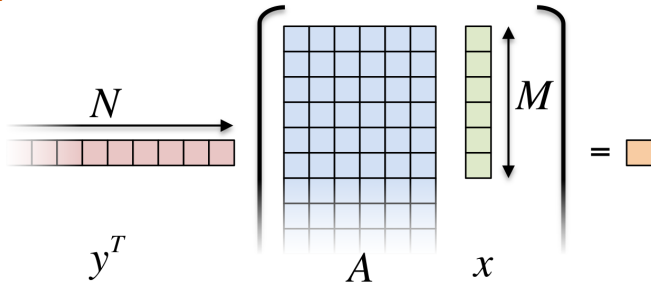

```

Kokkos::parallel_reduce("Label",
  RangePolicy<ExecutionSpace>(0, N),
  KOKKOS_LAMBDA (const size_t row, double & valueToUpdate) {
    double thisRowsSum = 0;
    for (size_t entry = 0; entry < M; ++entry) {
      thisRowsSum += A(row, entry) * x(entry);
    }
    valueToUpdate += y(row) * thisRowsSum;
  }, result);

```

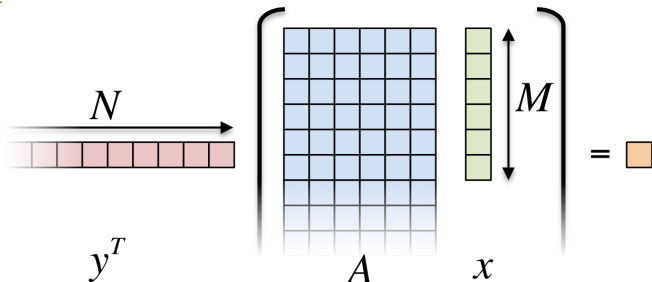

Driving question: How should A be laid out in memory?

Layout is the mapping of multi-index to memory:

LayoutLeft

in 2D, “column-major”

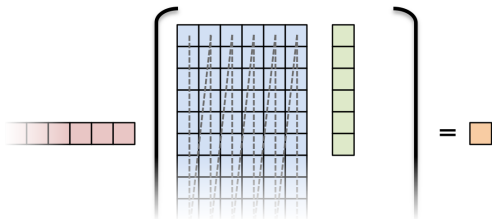

LayoutRight

in 2D, “row-major”

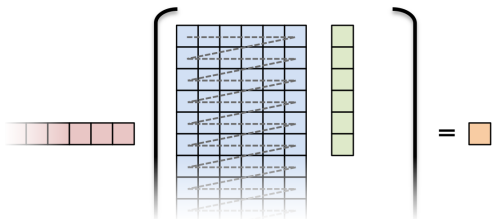

Important concept: Layout

Every View has a multidimensional array Layout set at compile-time.

```
View<double***, Layout, Space> name(...);
```

Important concept: Layout

Every View has a multidimensional array Layout set at compile-time.

```
View<double***, Layout, Space> name(...);
```

- ▶ Most-common layouts are `LayoutLeft` and `LayoutRight`.
 `LayoutLeft`: left-most index is stride 1.
 `LayoutRight`: right-most index is stride 1.
- ▶ If no layout specified, default for that memory space is used.
 `LayoutLeft` for `CudaSpace`, `LayoutRight` for `HostSpace`.
- ▶ Layouts are extensible: ≈ 50 lines
- ▶ Advanced layouts: `LayoutStride`, `LayoutTiled`, ...

Details:

- ▶ Location: Exercises/04/Begin/
- ▶ Replace ‘N’ in parallel dispatch with `RangePolicy<ExecSpace>`
- ▶ Add `MemSpace` to all Views and Layout to A
- ▶ Experiment with the combinations of `ExecSpace`, Layout to view performance

Things to try:

- ▶ Vary problem size and number of rows (-S ...; -N ...)
- ▶ Change number of repeats (-nrepeat ...)
- ▶ Compare behavior of CPU vs GPU
- ▶ On GPUs, compare using `SharedSpace` vs using the default memory space, i.e, not providing an explicit memory space.
- ▶ Check what happens if `MemSpace` and `ExecSpace` do not match.

Exercise #4: Inner Product, Flat Parallelism

<y|Ax> Exercise 04 (Layout) Fixed Size

KNL: Xeon Phi 68c HSW: Dual Xeon Haswell 2x16c Pascal60: Nvidia GPU

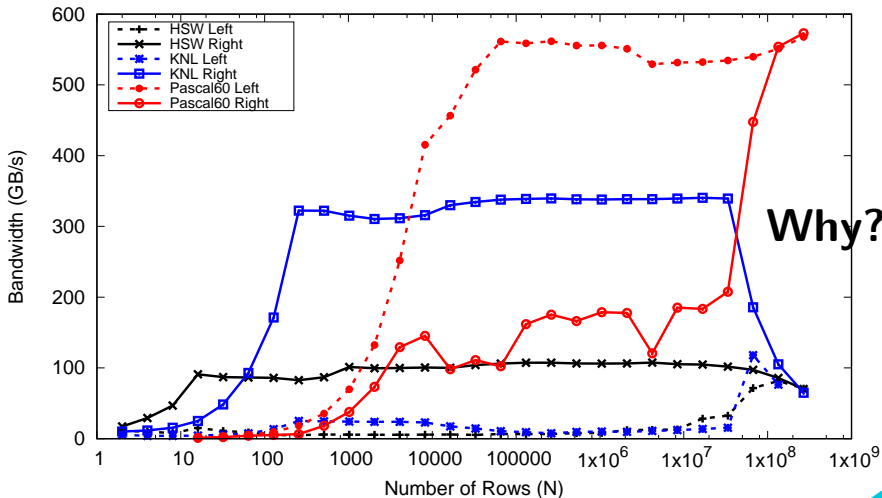

Thread independence:

```
operator()(int index, double & valueToUpdate) const {  
    const double d = _data(index);  
    valueToUpdate += d;  
}
```

Question: once a thread reads `d`, does it need to wait?

Thread independence:

```
operator()(int index, double & valueToUpdate) const {  
    const double d = _data(index);  
    valueToUpdate += d;  
}
```

Question: once a thread reads `d`, does it need to wait?

- ▶ **CPU** threads are independent.
 - ▶ i.e., threads may execute at any rate.

Thread independence:

```
operator()(int index, double & valueToUpdate) const {  
    const double d = _data(index);  
    valueToUpdate += d;  
}
```

Question: once a thread reads `d`, does it need to wait?

- ▶ **CPU** threads are independent.
 - ▶ i.e., threads may execute at any rate.
- ▶ **GPU** threads execute synchronized.
 - ▶ i.e., threads in groups can/must execute instructions together.

Thread independence:

```
operator()(int index, double & valueToUpdate) const {  
    const double d = _data(index);  
    valueToUpdate += d;  
}
```

Question: once a thread reads *d*, does it need to wait?

- ▶ **CPU** threads are independent.
 - ▶ i.e., threads may execute at any rate.
- ▶ **GPU** threads execute synchronized.
 - ▶ i.e., threads in groups can/must execute instructions together.

In particular, all threads in a group (*warp* or *wavefront*) must finish their loads before *any* thread can move on.

Thread independence:

```
operator()(int index, double & valueToUpdate) const {  
    const double d = _data(index);  
    valueToUpdate += d;  
}
```

Question: once a thread reads *d*, does it need to wait?

- ▶ **CPU** threads are independent.
 - ▶ i.e., threads may execute at any rate.
- ▶ **GPU** threads execute synchronized.
 - ▶ i.e., threads in groups can/must execute instructions together.

In particular, all threads in a group (*warp* or *wavefront*) must finish their loads before *any* thread can move on.

So, **how many cache lines** must be fetched before threads can move on?

CPUs: few (independent) cores with separate caches:

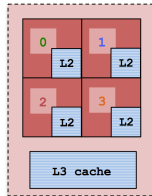
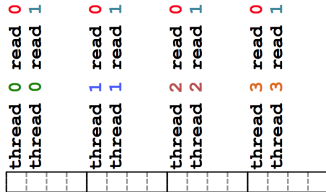

CPU: few (independent) cores with separate caches:

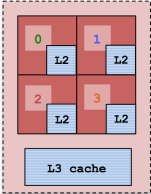
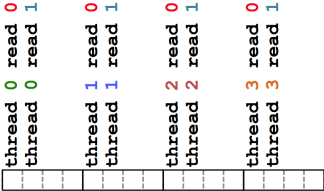

GPU: many (synchronized) cores with a shared cache:

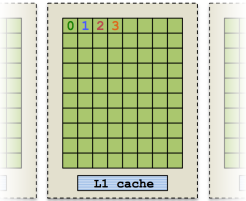
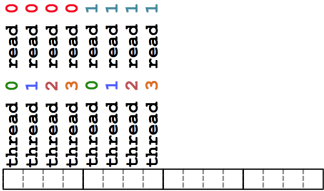

Important point

For performance, accesses to views in HostSpace must be **cached**, while access to views in CudaSpace must be **coalesced**.

Caching: if thread t 's current access is at position i , thread t 's next access should be at position $i+1$.

Coalescing: if thread t 's current access is at position i , thread $t+1$'s current access should be at position $i+1$.

Important point

For performance, accesses to views in HostSpace must be **cached**, while access to views in CudaSpace must be **coalesced**.

Caching: if thread t 's current access is at position i , thread t 's next access should be at position $i+1$.

Coalescing: if thread t 's current access is at position i , thread $t+1$'s current access should be at position $i+1$.

Warning

Uncoalesced access on GPUs and non-cached loads on CPUs *greatly* reduces performance (can be 10X)

Consider the array summation example:

```
View<double*, Space> data("data", size);
...populate data...

double sum = 0;
Kokkos::parallel_reduce("Label",
    RangePolicy< Space>(0, size),
    KOKKOS_LAMBDA (const size_t index, double & valueToUpdate) {
    valueToUpdate += data(index);
},
    sum);
```

Question: is this cached (for OpenMP) and coalesced (for Cuda)?

Consider the array summation example:

```
View<double*, Space> data("data", size);
...populate data...

double sum = 0;
Kokkos::parallel_reduce("Label",
    RangePolicy< Space>(0, size),
    KOKKOS_LAMBDA (const size_t index, double & valueToUpdate) {
        valueToUpdate += data(index);
    },
    sum);
```

Question: is this cached (for OpenMP) and coalesced (for Cuda)?

Given P threads, **which indices** do we want thread 0 to handle?

Contiguous:

0, 1, 2, ..., N/P

Strided:

0, N/P, 2*N/P, ...

Consider the array summation example:

```
View<double*, Space> data("data", size);
...populate data...

double sum = 0;
Kokkos::parallel_reduce("Label",
    RangePolicy< Space>(0, size),
    KOKKOS_LAMBDA (const size_t index, double & valueToUpdate) {
        valueToUpdate += data(index);
    },
    sum);
```

Question: is this cached (for OpenMP) and coalesced (for Cuda)?

Given P threads, **which indices** do we want thread 0 to handle?

Contiguous:

0, 1, 2, ..., N/P

CPU

Strided:

0, N/P, 2*N/P, ...

GPU

Why?

Iterating for the execution space:

```
operator()(int index, double & valueToUpdate) const {  
    const double d = _data(index);  
    valueToUpdate += d;  
}
```

As users we don't control how indices are mapped to threads, so how do we achieve good memory access?

Iterating for the execution space:

```
operator()(int index, double & valueToUpdate) const {  
    const double d = _data(index);  
    valueToUpdate += d;  
}
```

As users we don't control how indices are mapped to threads, so how do we achieve good memory access?

Important point

Kokkos maps indices to cores in **contiguous chunks** on CPU execution spaces, and **strided** for Cuda.

Rule of Thumb

Kokkos index mapping and default layouts provide efficient access if **iteration indices** correspond to the **first index** of array.

Example:

```
View<double***, ...> view(...);  
...  
Kokkos::parallel_for("Label", ... ,  
  KOKKOS_LAMBDA (int workIndex) {  
  ...  
  view(..., ... , workIndex ) = ...;  
  view(... , workIndex, ... ) = ...;  
  view(workIndex, ... , ... ) = ...;  
  });  
...
```

Important point

Performant memory access is achieved by Kokkos mapping parallel work indices **and** multidimensional array layout *appropriately for the architecture*.

Important point

Performant memory access is achieved by Kokkos mapping parallel work indices **and** multidimensional array layout *appropriately for the architecture*.

Analysis: row-major (LayoutRight)

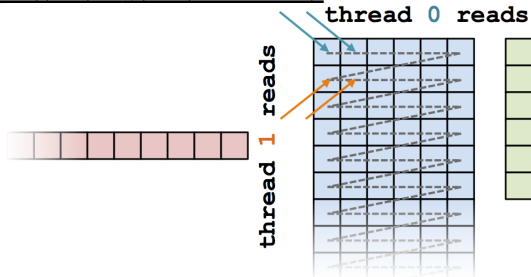

Important point

Performant memory access is achieved by Kokkos mapping parallel work indices **and** multidimensional array layout *appropriately for the architecture*.

Analysis: row-major (LayoutRight)

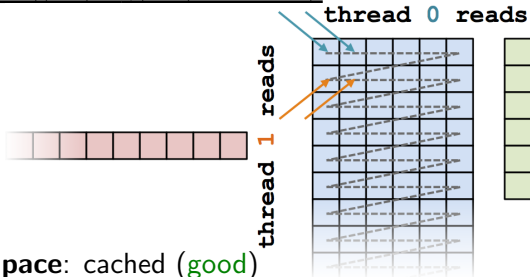

- ▶ **HostSpace**: cached (good)
- ▶ **CudaSpace**: uncoalesced (bad)

Important point

Performant memory access is achieved by Kokkos mapping parallel work indices **and** multidimensional array layout *optimally for the architecture*.

Analysis: column-major (LayoutLeft)

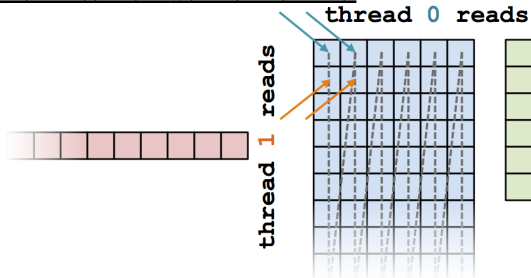

Important point

Performant memory access is achieved by Kokkos mapping parallel work indices **and** multidimensional array layout *optimally for the architecture*.

Analysis: column-major (LayoutLeft)

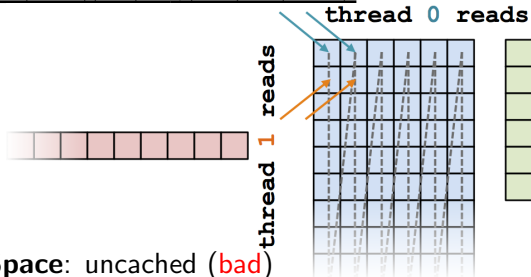

- ▶ **HostSpace**: uncached (**bad**)
- ▶ **CudaSpace**: coalesced (**good**)

Analysis: Kokkos architecture-dependent

```
View<double**, ExecutionSpace> A(N, M);
parallel_for(RangePolicy< ExecutionSpace>(0, N),
  ... thisRowsSum += A(j, i) * x(i);
```

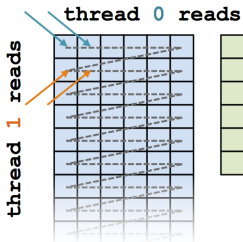

(a) OpenMP

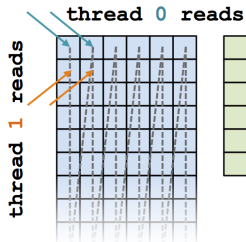

(b) Cuda

- ▶ **HostSpace**: cached (good)
- ▶ **CudaSpace**: coalesced (good)

<y|Ax> Exercise 04 (Layout) Fixed Size

KNL: Xeon Phi 68c HSW: Dual Xeon Haswell 2x16c Pascal60: Nvidia GPU

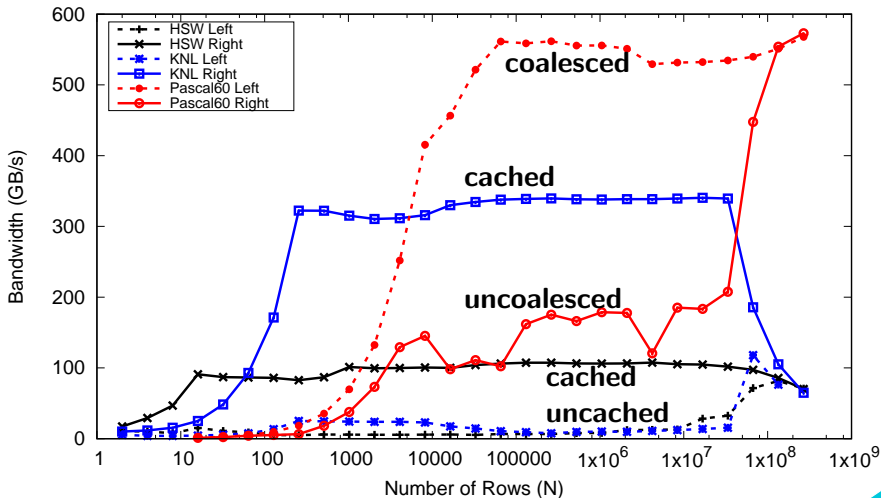

- ▶ Every View has a Layout set at compile-time through a **template parameter**.
- ▶ LayoutRight and LayoutLeft are **most common**.
- ▶ Views in HostSpace default to LayoutRight and Views in CudaSpace default to LayoutLeft.
- ▶ Layouts are **extensible** and **flexible**.
- ▶ For performance, memory access patterns must result in **caching** on a CPU and **coalescing** on a GPU.
- ▶ Kokkos maps parallel work indices *and* multidimensional array layout for **performance portable memory access patterns**.
- ▶ There is **nothing** in OpenMP, OpenACC, or OpenCL to manage layouts.
⇒ You'll need multiple versions of code or pay the performance penalty.

Advanced Reductions

Learning objectives:

- ▶ How to use Reducers to perform different reductions.
- ▶ How to do multiple reductions in one kernel.
- ▶ Using `Kokkos::View`'s as result for asynchronicity.
- ▶ Custom reductions

So far only "sum" reduction. What about other things?

Using a Reducer:

```
double max_value = 0;
parallel_reduce("Label", numberOfIntervals,
  KOKKOS_LAMBDA(const int64_t i, double & valueToUpdate) {
    double my_value = function(...);
    if(my_value > valueToUpdate) valueToUpdate = my_value;
  }, Kokkos::Max<double>(max_value));
```

So far only "sum" reduction. What about other things?

Using a Reducer:

```
double max_value = 0;
parallel_reduce("Label", numberOfIntervals,
  KOKKOS_LAMBDA(const int64_t i, double & valueToUpdate) {
    double my_value = function(...);
    if(my_value > valueToUpdate) valueToUpdate = my_value;
  }, Kokkos::Max<double>(max_value));
```

- ▶ Note how the operation in the body matches the reducer op!

So far only "sum" reduction. What about other things?

Using a Reducer:

```
double max_value = 0;
parallel_reduce("Label", numberOfIntervals,
  KOKKOS_LAMBDA(const int64_t i, double & valueToUpdate) {
    double my_value = function(...);
    if(my_value > valueToUpdate) valueToUpdate = my_value;
  }, Kokkos::Max<double>(max_value));
```

- ▶ Note how the operation in the body matches the reducer op!
- ▶ The scalar type is used as a template argument.

So far only "sum" reduction. What about other things?

Using a Reducer:

```
double max_value = 0;
parallel_reduce("Label", numberOfIntervals,
  KOKKOS_LAMBDA(const int64_t i, double & valueToUpdate) {
    double my_value = function(...);
    if(my_value > valueToUpdate) valueToUpdate = my_value;
  }, Kokkos::Max<double>(max_value));
```

- ▶ Note how the operation in the body matches the reducer op!
- ▶ The scalar type is used as a template argument.
- ▶ Many reducers available: Sum, Prod, Min, Max, MinLoc,
see: https://kokkos.github.io/kokkos-core-wiki/API/core/builtin_reducers.html

So far only "sum" reduction. What about other things? Using a Reducer:

```
double max_value = 0;
parallel_reduce("Label", numberOfIntervals,
  KOKKOS_LAMBDA(const int64_t i, double & valueToUpdate) {
    double my_value = function(...);
    if(my_value > valueToUpdate) valueToUpdate = my_value;
}, Kokkos::Max<double>(max_value));
```

- ▶ Note how the operation in the body matches the reducer op!
- ▶ The scalar type is used as a template argument.
- ▶ Many reducers available: Sum, Prod, Min, Max, MinLoc, see: https://kokkos.github.io/kokkos-core-wiki/API/core/builtin_reducers.html
- ▶ Some reducers (like MinLoc) use special scalar types!

So far only "sum" reduction. What about other things?

Using a Reducer:

```
double max_value = 0;
parallel_reduce("Label", numberOfIntervals,
  KOKKOS_LAMBDA(const int64_t i, double & valueToUpdate) {
    double my_value = function(...);
    if(my_value > valueToUpdate) valueToUpdate = my_value;
  }, Kokkos::Max<double>(max_value));
```

- ▶ Note how the operation in the body matches the reducer op!
- ▶ The scalar type is used as a template argument.
- ▶ Many reducers available: Sum, Prod, Min, Max, MinLoc, see: https://kokkos.github.io/kokkos-core-wiki/API/core/builtin_reducers.html
- ▶ Some reducers (like MinLoc) use special scalar types!
- ▶ Custom value types supported via specialization of `reduction_identity`.

Sometimes multiple reductions are needed

- ▶ Provide multiple reducers/result arguments
- ▶ Functor/Lambda operator takes matching thread-local variables
- ▶ Mixing scalar types is fine.

```
float max_value = 0;
double sum = 0;
parallel_reduce("Label", numberOfIntervals,
    KOKKOS_LAMBDA(const int64_t i, float& tl_max, double& tl_sum){
    float a_i = a[i];
    if(a_i > tl_max) tl_max = a_i;
    tl_sum += a_i;
}, Kokkos::Max<float>(max_value), sum);
```

Reducing into a Scalar is blocking!

- ▶ Providing a reference to scalar means no lifetime expectation.
 - ▶ Call to `parallel_reduce` returns after writing the result.
- ▶ `Kokkos::View` can be used as a result, allowing for potentially non-blocking execution.
- ▶ Can provide `View` to host memory, or to memory accessible by the `ExecutionSpace` for the reduction.
- ▶ Works with Reducers too!

```
View<double,HostSpace> h_sum("sum_h");  
View<double,CudaSpace> d_sum("sum_d");  
using policy_t = RangePolicy<Cuda>;  
  
parallel_reduce("Label", policy_t(0,N), SomeFunctor,  
  h_sum);  
  
parallel_reduce("Label", policy_t(0,N), SomeFunctor,  
  Kokkos::Sum<double, CudaSpace>(d_sum));
```

Pseudocode for Kokkos implementation

```
per_thread:  
  value& tmp=init(local_tmp);  
  for (i in local range)  
    functor(i, tmp)  
call join for merging values between threads  
  in the same thread group  
let one (the last) thread group merge all results  
  from all thread groups  
call final(result) on one thread
```

Three ingredients

- ▶ init (optional), default: default constructor
- ▶ join (required)
- ▶ final (optional), default: no-op

Rules for choosing reduction behavior

1. If a reducer is specified (return type is a functor with `reducer` alias to itself), use that.
2. If functor implements `join`, use functor as reducer.
3. Otherwise, assume `join` behaves like `operator+`.

Note that the functor's `init`, `join`, `final` members must be tagged if the call operator is tagged. The `reducers` member functions must never be tagged.

```
class Reducer {
public:
    using reducer      = Reducer;
    using value_type = ... ;
    using result_view_type = Kokkos::View<value_type, ... >;

    KOKKOS_FUNCTION
    void join(value_type& dest, const value_type& src) const;

    //optional
    KOKKOS_INLINE_FUNCTION
    void init(value_type& val) const;

    //optional
    KOKKOS_INLINE_FUNCTION
    void final(value_type& val) const;

    KOKKOS_INLINE_FUNCTION
    value_type& reference() const;

    KOKKOS_INLINE_FUNCTION
    result_view_type view() const;

    KOKKOS_INLINE_FUNCTION
    Reducer(value_type& value_);

    KOKKOS_INLINE_FUNCTION
    Reducer(const result_view_type& value_);
};
```

Kokkos View

- ▶ Multi Dimensional Array.
- ▶ Compile and Runtime Dimensions.
- ▶ Reference counted like a `std::shared_ptr` to an array.

```
Kokkos::View<int*[5]> a("A", N);  
a(3,2) = 7;
```

Execution Spaces

- ▶ Parallel operations execute in a specified **Execution Space**
- ▶ Can be controlled via template argument to **Execution Policy**
- ▶ If no Execution Space is provided use
`DefaultExecutionSpace`

```
// Equivalent:  
parallel_for("L", N, functor);  
parallel_for("L",  
    RangePolicy<DefaultExecutionSpace>(0, N), functor);
```

Memory Spaces

- ▶ Kokkos Views store data in **Memory Spaces**.
- ▶ Provided as template parameter.
- ▶ If no Memory Space is given, use `Kokkos::DefaultExecutionSpace::memory_space`.
- ▶ `deep_copy` is used to transfer data: no hidden memory copies by Kokkos.

```
View<int*, CudaSpace> a("A", M);  
// View in host memory to load from file  
auto h_a = create_mirror_view(a);  
load_from_file(h_a);  
// Copy  
deep_copy(a, h_a);
```

Layouts

- ▶ Kokkos Views use an index mapping to memory determined by a **Layout**.
- ▶ Provided as template parameter.
- ▶ If no **Layout** is given, derived from the execution space associated with the memory space.
- ▶ Defaults are good if you parallelize over left most index!

```
View<int**, LayoutLeft> a("A", N, M);
View<int**, LayoutRight> b("B", N, M);

parallel_for("Fill", N, KOKKOS_LAMBDA(int i) {
    for(int j = 0; j < M; j++) {
        a(i,j) = i * 1000 + j; // coalesced
        b(i,j) = i * 1000 + j; // cached
    }
});
```

Advanced Reductions

- ▶ `parallel_reduce` defaults to summation
- ▶ Kokkos reducers can be used to reduce over arbitrary operations
- ▶ Reductions over multiple values are supported
- ▶ Only reductions into scalar arguments are guaranteed to be synchronous
- ▶ Support for custom reductions

```
parallel_reduce("Join", n,  
  KOKKOS_LAMBDA(int i, double& a, int& b) {  
    int idx = foo();  
    if(idx > b) b = idx;  
    a += bar();  
  }, result, Kokkos::Max<int>{my_max});
```

Advanced Data Structures

- ▶ Subsetting and slicing of Views
- ▶ Higher-level and special purpose View data structures
- ▶ Atomic access to a View's data

More Parallel Policies:

- ▶ Multidimensional loops with MDRangePolicy

Slack channel: <https://kokkosteam.slack.com/>

Recordings/Slides:

<https://kokkos.org/kokkos-core-wiki/videolectures.html>